

No.	DESCRIPTION	MATERIAL
1	STEM	LOW LEAD BRASS ALLOY
2	O-RING	EP ASTM D2000
3	BALL	LOW LEAD BRASS ALLOY
4	RUBBER GASKET	RUBBER CODE R80
5	BODY	CAST LOW LEAD BRASS ALLOY
6	O-RING	EP ASTM D2000
7	END PIECE	CAST LOW LEAD BRASS ALLOY
8	COMP GASKET	RUBBER CODE R93
9	WASHER	POLYPROPYLENE
10	COUPLING NUT	CAST BRASS ASTM B62 ALLOY C83600
11	CAP SCREW	304 STAINLESS STEEL

SIZE	ØA	B	C	D
3/4"	.75	3.83	1.39	.84
1"	1.00	4.20	1.59	1.15
1-1/2"	1.50	5.50	2.24	1.50
2"	2.00	6.57	2.27	1.82

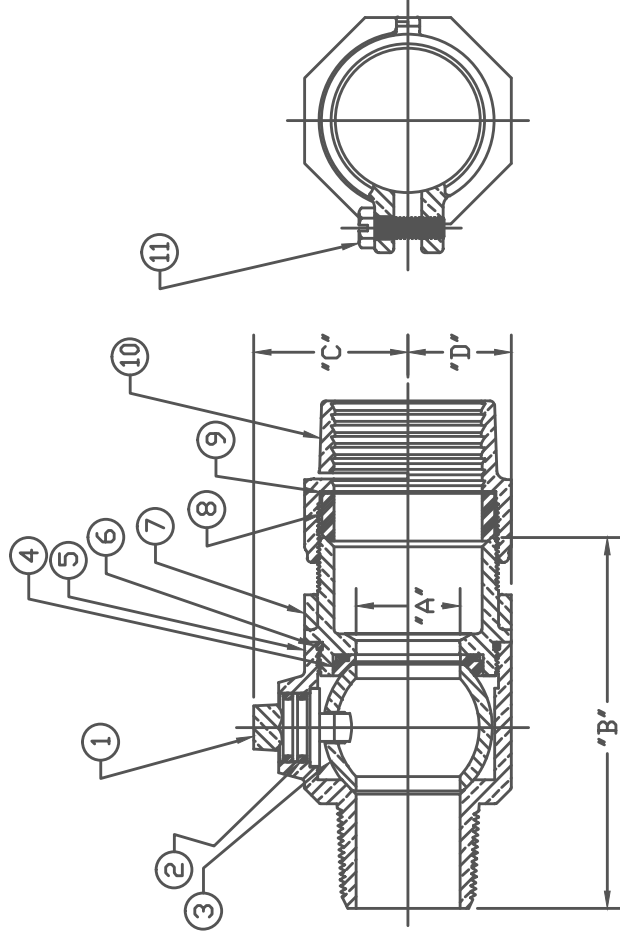

NOTE: ALL WETTED PARTS ARE LOW LEAD BRASS ALLOY

FILEPATH: PROD-ENGMUELLER\SUBASSEMBLY\E25009N

DRFTR	Garv/rh	1/23/12
CHKR		
ENGR		
MGR		
BY		DATE
STK No		
MAT'L		

UNLESS OTHERWISE NOTED  
 SURFACE PREPARATION  
 BREAK CORNER(S) --- .000  
 SURFACE FINISH --- XX RMS  
 TOLERANCE(S)  
 LINEAR ----- ± .000  
 ANGULAR ----- ± 0'00"

THIRD ANGLE PROJECTION

SCALE  
 NONE  
 PLOT  
 HALF

REF. No.

Mueller Co.

REV	ECR	DESCRIPTION	DATE	BY	CHKR

DESCR. BALL CORPORATION VALVE - LLB  
 (CC x PEP/PVCKIPS) PACK JOINT)

PART NUMBER E25009N

PER EST NO: XXXX EST F'IN WT = 0.0000 lbs

4<sup>th</sup>-MRKTING  
 E25009N  
 PART NUMBER